

# NAUSICAA

MEDICAL

[www.nausicaa-medical.com](http://www.nausicaa-medical.com)

NAUSICAA Médical est certifiée ISO 13485

## STAND-UP LIFT: **EASYLEV 5 FIXED OR WITH MECHANICAL OR ELECTRIC ECP**



MADE OF STEEL

MAXIMUM CAPACITY: 180 kg

CLASS 1 MEDICAL DEVICE

ALL OUR APPLIANCES COMPLY WITH THE NF EN ISO 10535 : 2021 STANDARD.

# Contents

## User Manual / Stand-Up Lift: EASYLEV 5 Range

• Use .....	p.01
Contraindication .....	
Scope of Delivery .....	
• Assembling Instructions .....	p.02
- Range EASYLEV5 (1 part assembly) .....	p.02
- Range EASYLEV5 (2 parts assembly) .....	p.03-04
• Parking Brake .....	p.04
• Instructions for use .....	p.05
• Stand-up Lifts Use .....	p.06
• Motorisation Informations .....	p.08
• Slings Use .....	p.09
• Reuse .....	p.11
• Labeling .....	p.11
• General Safety Guidelines .....	p.14
• Technicals & Dimensionals Characteristics .....	
EASYLEV5 .....	p.15
EASYLEV5 with mechanical opening legs, .....	p.16
EASYLEV5 PLUS with electrical opening legs .....	
• Technicals & Dimensionals Characteristics .....	p.17
Battery Charging Diagram .....	p.17
• Cleaning & Maintenance .....	p.19
• Preventive Maintenance & Security Controls .....	p.20
• Spare Parts .....	p.23
- EASYLEV5 .....	
EASYLEV5 with mechanical opening legs, .....	p.24
EASYLEV5 PLUS with electrical opening legs .....	p.25
- Control Box .....	p.26
- Remote Control .....	p.28
- Jack 3 000 Newtons .....	p.29
- Opening Legs Jack 3 000 Newtons .....	p.30
• Troubleshooting Guide .....	p.31
• Warranty .....	p.33

The logo for Easyler, featuring the brand name in a stylized, blue, handwritten-style font.

# Use

This user manual contains important information on handling the product. To ensure safe use of the product, read the product carefully and follow the safety instructions.

The stand-up lift of the EASYLEV 5 range are class I medical devices. The stand-up lift can be used in hospitals, clinics, retirement homes, nursing homes, at home and must be handled by a health professional. It is designed for short-term use with a suitable strap. The maximum working load is 180 kg.

The climatic conditions for use of the EASYLEV 5 range are as follows: ambient temperature of 0 ° C to 40 ° C, humidity of 20% to 80% and air pressure of 700 to 1060 hPa.

The device can be used in the bathroom (without contact with water) or the toilet.

Verticalizers allow the patient to be raised from a bed, a chair, a toilet or a wheelchair to be transferred while being active.

## Contraindication

Diseases such as osteogenesis imperfecta, osteoporosis, spinal cord disease, mental illness or epilepsy may be contraindications.

## Scope of delivery

The stand-up lift has already been inspected at the factory to ensure that it is free from defects and that nothing is missing. Nevertheless, please check the product immediately after receipt for any damage which may have occurred during transport.

Use the delivery note to check that all items are present and that the delivery is thus complete.

Box	Contents	Units
STAND-UP LIFT : EASYLEV 5 RANGE	STAND-UP LIFT EASYLEV 5 RANGE	1
	BATTERY PACK (REMOVABLE)	1
	HOOK CABLE RETRACTOR	1
	POWER CORD	1
	CALE GUARDS	1
	HANDCONTROL	1
	USER MANUAL	1

# Assembling instructions range EASYLEV 5 (1 part assembly)

---

BEFORE USING YOUR STAND-UP LIFT, IT IS NECESSARY TO CHECK :

- The wheels turn and roll normally.
- The rear wheels function correctly.
- There is no wear or deformation on the hooks.

**WARNING :**

- To preserve the inserts, do not overtighten.
  - Assembly is done with the brakes locked.
- 

## **Step 1 :**

The device is ready to use.



# Assembling instructions range EASYLEV 5 (2 parts assembly) 1/2

---

**BEFORE USING YOUR STAND-UP LIFT, IT IS NECESSARY TO CHECK :**

- The wheels turn and roll normally.
- The rear wheels function correctly.
- There is no wear or deformation on the hooks.

---

**Step 1:**

You receive the device in 3 different parts to assemble, a base, a zinc-plated mast + a mobile mast and a knee support.



---

**Step 2:**

Insert the zinc-plated mast into the base then insert the M10 axis, a 1mm thickness plastic washer then an M10 lock nut on each side, tighten and then insert the nutcaps.

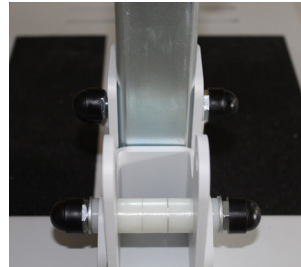

---

**Step 3:**

Insert the M8 screw under the base in the zinc-plated mast.

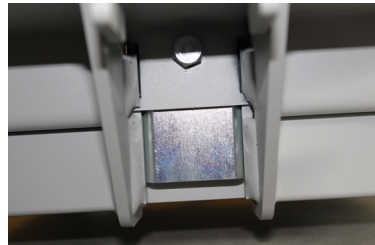

---

**Step 4:**

Insert the mobile mast on the zinc-plated mast, taking care not to peel off the rear part.



# Assembling instructions range EASYLEV5 (2 parts assembly) 2/2

## Step 5:

Insert the sling on the axis, a 3mm thickness plastic washer on each side, tighten then insert the nutcaps.



## Step 6 :

Insert the knee support, the device is ready to use.



## Parking brake

The parking brakes are one of the important safety elements of an stand-up lift. The rear castors are fitted with parking brakes which act directly on the wheels. To lock the castors, press the parking lever to the stop using your foot (Castor Locked). The stand-up lift can no longer be pushed in this setting.

To release the castors, press the parking lever pointing upwards (Castor Released).

When locking the castors always insure that both castors are locked.

If only one castor is locked on a sloping floor, the unlocked wheel will roll downhill around the locked wheel.

Depending on the slope of the surface, there is the danger that the stand-up lift will tip over sideways.

Models	Castor Released	Castor Locked
<p><b>EASYLEV5, EASYLEV5 with mechanical opening legs, EASYLEV5 PLUS with electrical opening legs</b></p>		

# Instructions for use

---

Your stand is designed to lift people, so do not use it for other purposes.

- Check that the patient's weight does not exceed the maximum weight that the lifter can lift.
- Do not force the controls and devices of the stand, they are all easy to use and do not need force.
- Maneuver the stander by pushing the handles or handles, never pushing the patient.
- Carefully manipulate the stander when transferring a patient and at a speed appropriate to the situation.
- Move with the stand on flat, smooth surfaces. It is not recommended to use it on a slope of more than 5 °: if you are obliged to circulate on a ramp, it is advised that a second person helps you. Never use an electric stander under a shower.
- Never charge a stand-up battery near a bath or shower.

## Instructions for use

---

- The stand-up lifts are useful and effective when a patient has a certain degree of dependence coupled with a caregiver need for basic care.
- They are designed for patients whose mobility is reduced but who can however be supported temporarily on at least one leg (a minimum of tonicity by the patient is required), and who require mechanical assistance to be put into standing and be moved.
- The stand-up lifts contribute to the stimulation of the patient and its mobility; stimulate the cardiac system; combating against osteoporosis and all disorders associated with immobility such as falls during transfers; stimulate brain activity thus favouring maintenance of continence; improves intestinal activity and bladder function.
- Using a stand-up lift requires a capacity assessment of the patient.
- When using a stand-up lift, patients can be categorized in 2 categories:
  1. Low-tonicity patients
  2. Medium-tonicity patients
- How to properly use a stand-up lift (1.):
  - Low-tonicity patients shall be transferred in a "semi-seated" position



Example with a EASYLEV 5 with Mechanical opening legs

# Stand-up lifts use

- How to properly use a stand-up lift (2):
  - Medium-tonicity patients shall be transferred in a standing position



- Furthermore, the handlebar must be used to push and/or pull the device with the hands on the upper part or on the sides, **not below pushing upward**.



- Likewise, the patient's shins must be in contact with the shin block at all times.
- In all cases, the caregiver must be properly trained for the safe handling of the device.





# Stand-up lifts use



Control Box 2 Functions



Control Box 4 Functions

Before use, check that the actuator and the handcontrol are correctly connected to the control unit (page 17)  
Check the status of the control box and the battery

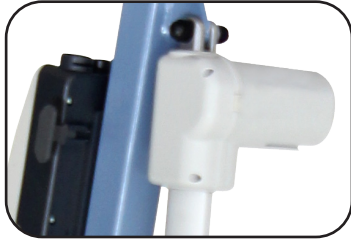

Check that the actuator is properly secured



Check that the battery is charged



# Motorisation informations

Lead Model  
Without Display

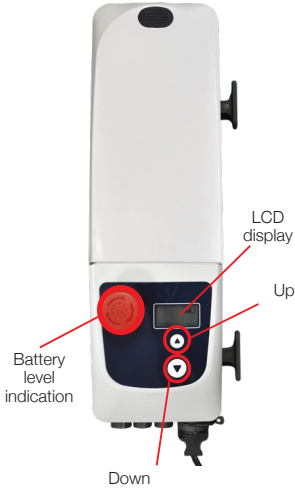

The products concerned are:  
EASYLEV5, EASYLEV5 with mechanical opening legs

Lithium Model  
With 2 Functions Display



The products concerned are:  
EASYLEV5, EASYLEV5 with mechanical opening legs

Lithium Model  
With 4 Functions Display



The products concerned are:  
EASYLEV5 Plus with electrical opening legs

Model with display  
2 functions

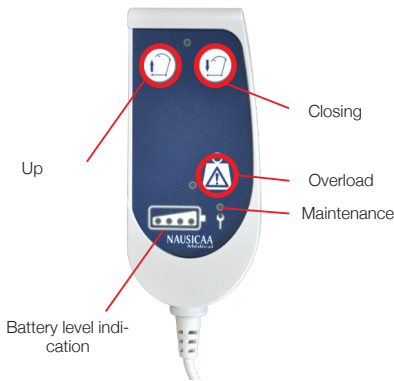

The products concerned are:  
EASYLEV5, EASYLEV5 with mechanical opening legs

Model with display  
4 functions

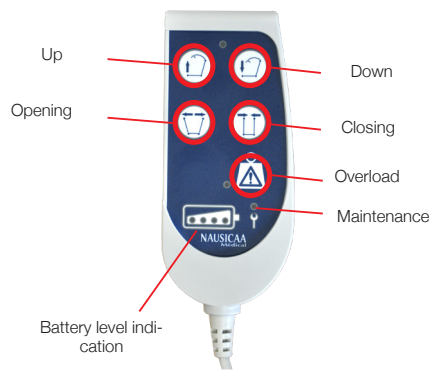

The products concerned are:  
EASYLEV5 Plus with electrical opening legs

# Slings use

## INSTRUCTIONS FOR USE

Position the bottom of the backrest in the lumbar region in order that the ears of the attachment system are on either side of the person.  
Place the fasteners of the backrest under the arms of the person.  
Close the plastron.  
Hook the two fasteners of the backrest to the stand-up lift hooks.

## SETTINGS

The fastening system, with multiple hangers, allows to adjust the position of the person.



## Transfer in sitting position for ALL PATIENTS



Position the “under thighs” strap and close it adjusting it without tightening too much.



Handlebar in lower position:  
Position the **yellow loops** on the central hooks of the handlebar.



Operate the actuator until halfway.

## Standing up for PATIENT WITH CHEST TONICITY



Handlebar in lower position:  
Position the **green loops** on the central hooks of the handlebar.

Operate the actuator until it stops.



# Slings use

Choosing the right sling size is important in order to achieve the highest possible patient comfort and safety.

SIZES	TU	S	M	L	XL	2XL	3XL	4XL
WAIST SIZE	70/140	70/90	90/115	115/140	140/165	154/186	172/206	196/232
BETWEEN SIZE AND HIPS	70/140	70/90	90/115	115/140	140/165	154/186	172/206	196/232

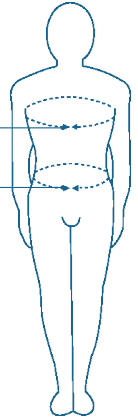

An assessment of the patient capacity is required before using a stand-up lift and more precisely to make sure that the patient can bear weight on at least one leg and has sufficient tonicity in the lower and upper parts of the body.

Our R&D department has put in place a size colour-code in order to quickly identify the size of each sling:

- Size TU (One size fits) Black
- Size S Yellow
- Size M Red
- Size L Green
- Size XL Blue
- Size 2XL Orange Light
- Size 3XL Orange
- Size 4XL Orange Dark

## CAUTION

### Important Recommendations

In order to get a maximum efficiency of these sort of product, it is necessary :

- to choose the appropriate size for the patient
  - to get the best possible adjustment to the patient
- These products must not be in direct contact with a wounded skin.

Read the instruction manual before using the slings.

The backrest hangers must be hung on the same color.

Before lifting a person with the stand-up lift, make sure the sling is securely hooked to the hooks.

# Reuse

The stand-up lift is suitable for repeated use.

The stand-up lift must be cleaned, disinfected and serviced according to the Preventive Maintenance and Security Controls (pages 14-15) at the very latest just before the reuse.

# Labelling

Labelling on the box

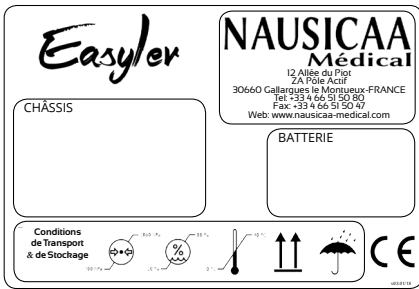

# Labelling



## SAFETY INSTRUCTIONS BEFORE EACH USE

**NAUSICAA**  
Medical

1

- Check the perfect condition of the hoist sling.
- Check the perfect condition of the traction sling (EASYLEV, NAUSILEV).
- Verify the presence and conditions of safety devices: all axis and their constrained fixations (pins, clips and bolts) and the tightness of the screws (see user manual).

DO NOT USE THE DEVICE IN CASE OF ANY LACK OR BAD OVERALL STATE

# Easylev

2

POIDS MAXIMUM  
MAXIMUM WEIGHT  
MAXIMALE TRAGFÄHIGKEIT  
PESO MAXIMO  
PESO MASSIMO

3

**180 kg**

CE NAUSICAA Medical FRANCE  
v10115-5



## BATTERY MAINTENANCE

**NAUSICAA**  
Medical

4

A POORLY MAINTAINED BATTERY DETERIORATES

- Regularly recharge the battery at the maximum.
- Making small incomplete charges shortens the battery life.
- The battery should not be exposed to temperatures neither too low nor too high.
- The batteries status depends on the maintenance and therefore can not be under warranty.
- It is important to check the charger if the battery no longer works.



5

wayp

CE

NAUSICAA MEDICAL  
15, av. du 11<sup>oct</sup> - 93 104 Aulnay  
Sous-Bois  
FRANCE

WAYUP-SB-PF

6



W5-12987-FM

Jahr/Monat Fertigung : 2019/08  
Maximallast : 180 kg



7



8

# Labelling

For all models of the EASYLEV 5 Range



# General safety guidelines

---

1. Use the Stand-Up Lift only for its intended purpose, in accordance with the legislation for medical devices, the regulations for labor protection and accident prevention, as well as the generally recognized rules of technology.
2. Note that the Stand-Up Lift is a medical device, therefore the user is required to comply with the directive on the use of medical devices.
3. The requirements for the electrical installation of the room or area where the Stand-Up Lift is used must meet the current state of the technology.
4. Using the Stand-Up Lift only after being trained for its handling.
5. Before using the device, please read the complete User Manual in order to avoid damage due to improper handling or exposure to risks. The User Manual contains important information and notes required for the Stand-Up Lift use.
6. Use the Stand-Up Lift in accordance with this User Manual only. Keep the User Manual for future reference in case of questions. Join this User Manual to the Stand-Up Lift in case of change of ownership.
7. Before any use, it must be ascertained whether the Stand-Up Lift and its accessories are in working order and in impeccable conditions.
8. Before using the Stand-Up Lift with other medical and non-medical devices, check that the combination of these products is allowed and can be used together safely.
9. Assembly, commissioning, maintenance and repair of the Stand-Up Lift should be entrusted only to specialists.
10. It is up to the user or operator to ensure (through adequate measures and instructions) that mechanical stress of the charging cord (through bending, tension, shear, crushing) is excluded during loading or cleaning of the part. This also applies to the electrical cables of other devices used with the Stand-Up Lift.
11. Respect the activation duration and the maximum weight capacity. These values must not be exceeded, otherwise the Stand-Up Lift safe operation is no longer guaranteed.
12. Do not expose the Stand-Up Lift to direct sunlight or heat.
13. Ensure that no moisture enters the electrical system.
14. Avoid mechanical stress on electrical cords. Pull, bend or crush the cords may damage them.
15. Charge batteries in a well ventilated area.
16. Electromagnetic interferences can not be excluded from the Stand-Up Lift and other devices. If there is a risk of such interference, the source of interference must be removed or the Stand-Up Lift should not be used.
17. Disruptions caused by the use of portable communication devices can not be completely excluded. This is why a safe distance of at least 3 meters must be kept in order to ensure the functioning of the Stand-Up Lift safely.
18. Do not leave unattended children stand near the Stand-Up Lift.
19. The Stand-Up Lift should not be used as soon as abnormal noises, damages or any other malfunctions occur. In this case, do not connect the wall charger to the Stand-Up Lift and inform us.
20. If damaged or defective, the Stand-Up Lift should not be used and should not be connected to the direct current. Inform the dealer to remedy the default or failure.



# Technicals and dimensionals characteristics

## MODELS CONCERNED EASYLEV5 FIXED BASE

- Frame made in steel
- Laser cutting and bending sheet metal, tubes and profiles
- Epoxy baked painting
- Ball bearing castors
- Lifespan : 8 years (except electrical parts)
- \* SCP : Suspension central point



the dimensions are in millimeters	EASYLEV5-SB-PF
Cylinder distance at maximum reach	Position 1 : 665 Position 2 : 685 Position 3 : 710
Base distance at maximum range	Position 1 : 630 Position 2 : 620 Position 3 : 675
Maximum height	Low handles Position 1 : 1475 Position 2 : 1500 Position 3 : 1525  Handles high Position 1 : 1500 Position 2 : 1520 Position 3 : 1545
Minimum height	Low handles 780  Handles high 890
lifting amplitude	565
maximum width	565
Distance from base to internal width 700mm (applicable to foot gauge versions) / minimum external width (fixed versions)	340
internal width at maximum range	240
minimum interior width	240
ground clearance	28
foot height	65
distance from the device to the maximum height	455
distance from the device to the maximum range	565
rounding diameter	900
total length	840
total width closed feet	1210
Maximum charge	180kg
Total weight of the device	38kg
Mass of the heaviest piece	

# Technicals and dimensionals characteristics

## MODELS CONCERNED EASYLEV5 with mechanical opening legs, EASYLEV5 PLUS with electrical opening legs

- Frame made in steel
- Laser cutting and bending sheet metal, tubes and profiles
- Epoxy baked painting
- Ball bearing castors
- Lifespan : 8 years (except electrical parts)
- \* SCP : Suspension central point



the dimensions are in millimeters	EASYLEV5ECP-SB-PF	EASYLEV5PLUS-SB-PF
Cylinder distance at maximum reach	Position 1 : 665 Position 2 : 685 Position 3 : 710	Position 1 : 665 Position 2 : 685 Position 3 : 710
Base distance at maximum range	Position 1 : 630 Position 2 : 620 Position 3 : 675	Position 1 : 630 Position 2 : 620 Position 3 : 675
Maximum height	Low handles Position 1 : 1490 Position 2 : 1515 Position 3 : 1540  Handles high Position 1 : 1535 Position 2 : 1560 Position 3 : 1580	Low handles Position 1 : 1490 Position 2 : 1515 Position 3 : 1540  Handles high Position 1 : 1535 Position 2 : 1560 Position 3 : 1580
Minimum height	Low handles 745  Handles high 850	Low handles 745  Handles high 850
lifting amplitude	880	765
maximum width	890	800
Distance from base to internal width 700mm (applicable to foot gauge versions) / minimum external width (fixed versions)	385	500
internal width at maximum range	780	700
minimum interior width	350	350
ground clearance	55	55
foot height	110	110
distance from the device to the maximum height	420	420
distance from the device to the maximum range	530	530
rounding diameter	1105	1105
total length	995	995
total width closed feet	1260	1260
Maximum charge	180kg	180kg
Total weight of the device	42kg	44kg
Mass of the heaviest piece		

# Technical and dimensionals characteristics

- Removable battery pack
  - Digital display of the autonomy
  - Emergency stop
  - Electrical security lowering system
  - Wall charger (in option)
  - Remote control 4 functions
  - Conform to Standard EN 60601-1
  - DC motor low voltage 24V
  - 24V / 120VA power
  - Maximum strength: 3000 N
  - Electrical opening actuator power: 3000 N
- (Models : EASYLEV5 with electrical opening legs)
- Lifting stroke : 49 cm
  - Electronic protection when overloaded
  - Protections types :
    - Télécommande: IP56
    - Remote control: IP54
    - Control box: IP65
    - Battery pack: IP65
    - Actuator: IP55
  - Stop limit switch
  - Box in ABS
  - Handcontrol with spiral cable, low voltage 24V
  - Protection against overloading through thermo-switch
  - Loudness : less than 55dB at a distance of 1 meter.
  - Electromagnetic compatibility : conforms to EN 60601-1-2



Device of  
class II



## Battery charging diagram :



# Motorisation technicals characteristics

Detail of the features of the Control Box:

1. Display information:

- To view the information stored in the control box, press the Up and Down buttons on the housing for 5 seconds.



2. Factor of operation:

- Recognizes for the cylinder (Up / Down) the non-compliance with the rest time of the cylinder.



3. Overloading cylinder # 1:

- Counts the number of times an attempt to transfer a person weighing beyond the maximum limit reached is made. When this is the case, the cylinder will stop and an anvil will be displayed. It will then be impossible to continue the operation of the device.



4. Overload of cylinder # 2:

- Count the number of times an attempt is made to move or close the feet while the feet are stuck. When this is the case, the cylinder will stop and an anvil will be displayed. It will then be impossible to continue the operation of the device.



5. Incomplete charge:

- Counts all incomplete charges in the battery below 24.6V. This number corresponds to the number of charges that damage the battery.

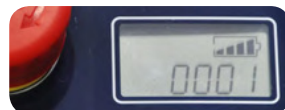

6. Usage time:

- Displays the cumulative usage time of the device. From 600,000 seconds of use, the maintenance key is displayed - it is necessary to perform a complete control of the device.



7-List of error codes:

E001: Required time setting

E002: Low battery charge level

E003: Abnormal operating time (duty factor)

E004: Cylinder overload N ° 1

E005: Cylinder overload N ° 2

E006: Maintenance required (600,000 seconds)

# Cleaning and Maintenance

---

## BEFORE ANY HANDLING:

- Disconnect the AC power cord.
- Check that all electrical components are connected to each other.

## CLEANING PROCESS:

- Clean the surfaces with a wet cloth by using an appropriate detergent.
- A regular cleaning is recommended.

## DAILY MAINTENANCE:

- By means of a product applied on the surface in one operation.
- After the patient's discharge by respecting the following operation:
  - Cleaning is carried out by means of a cloth impregnated with a disinfectant solution surface.
- Maintenance by specific service providers after removal of the stand-up lift from the facility:
  - Biological cleaning operation
  - Steam cleaning of various flat surfaces. Change surfaces regularly when washing to avoid water load. Steam cleaning of inaccessible areas. For tubes, steam use with a microfiber mop. Do not direct steam directly on the electrical boxes.

## MONTHLY MAINTENANCE:

- Check that the device does not present any visible damages.
- Check that no part is missing.
- Check the good functioning of the castors and that no matter prevents their bearing.
- Check the good functioning of the commands as well as the connections of the remote control and the actuator on the battery.
- Clean the sockets and the commands buttons with a dry cloth, if needed with a wet cloth.
- Check the good state of the electric cables.

## CAUTION:

- Disinfection of actuators, electrical boxes and handsets with a microfiber cloth impregnated with disinfectant.

If you notice a fault, contact the S.A.V.

Verticalisateurs & Lève-Personnes  
Téléphone : 04 66 71 71 80  
Fax : 04 66 71 71 81  
Mail : sav@nausicaa-medical.com

# Preventive maintenance and security controls

Date intervention :

Service provider's stamp	First name and surname of consultant
Name of establishment referent	Room number :
Brand : Model: Equipment no. : Manufacturer series no. :	<input type="checkbox"/> Leased equipment : <input type="checkbox"/> Owned equipment :

	Description	Compliant	Not compliant	Diagnostic
<b>1</b>	Checking the cylinder/lifting arm assembly			
<b>2</b>	Checking the cylinder/mast assembly			
<b>3</b>	Checking the mast/lifting arm assembly			
<b>4</b>	Checking the mast/ crusher assembly(s)			
<b>5</b>	Checking the mast/ handlebar assembly			
<b>6</b>	Checking wheel fixing			
<b>7</b>	Checking sub-patellar support fixation			
<b>8</b>	Checking sling suspension hooks			
<b>9</b>	Check structural condition and paintwork			
Additional checks for models with opening legs :				
<b>10</b>	Check Pedal or Foot Spacer Assembly			
<b>11</b>	Checking the foot spacer system			
<b>12</b>	Checking left and right foot assemblies			
	Check lifting cylinder operation			
	Check remote control (function and status)			
	Check control box (emergency stop button, etc.)			
	Battery check (3 complete cycles)			
	Optional : Checking operation of foot spreader cylinder			
	Observation <input type="checkbox"/> Breakage Customer misuse <input type="checkbox"/> Wear <input type="checkbox"/> Equipment replaced by N°.			

Checks done on:	Checks made by:	Scheduled date of next check:
-----------------	-----------------	-------------------------------

# Preventive maintenance and security controls

## EASYLEV5

Assembly to lubricate	No. on Diagram
Assembly Cylinder / Lift Arm	1
Assembly Cylinder / Mat	2
Assembly Mat / Lift Arm Wheel	3
Pivot	4
Support slide under patellar	5

Periodic lubrication:  
Use a «3 in 1» product or similar

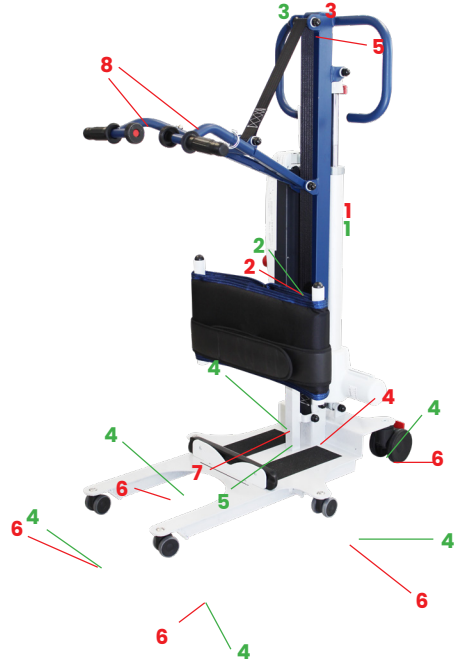

## EASYLEV5 with mechanical opening legs

Assembly to lubricate	No. on Diagram
Cylinder / Lift Arm Assembly	1
Cylinder / Mat Assembly	2
Mat / Lift Arm Assembly	3
Pivot of wheels	4
Sub-patellar support slide	5
ECP Pedal or Cylinder Assembly Foot Spacer	6
System	7
Assemblies of the right and left feet on Embase	8

Periodic lubrication:  
Use a «3 in 1» product or similar

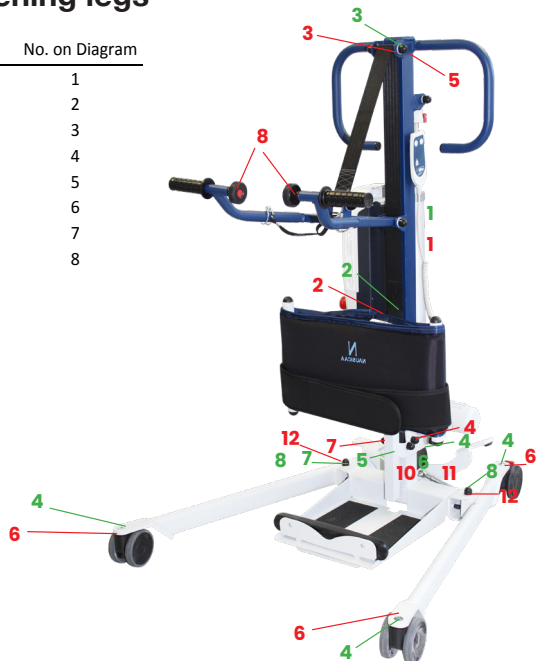

# Preventive maintenance and security controls

## EASYLEV5 PLUS with electrical opening legs

Assembly to lubricate	No. on Diagram
Cylinder / Lift Arm Assembly	1
Cylinder / Mat Assembly	2
Mat / Lift Arm Assembly	3
Pivot of wheels	4
Submarine support runner	5
ECP Pedal or Cylinder Assembly Foot Spacer System	6
	7
Assemblies of the right and left feet on Embase	8

Periodic lubrication:  
Use a «3 in 1» product or similar

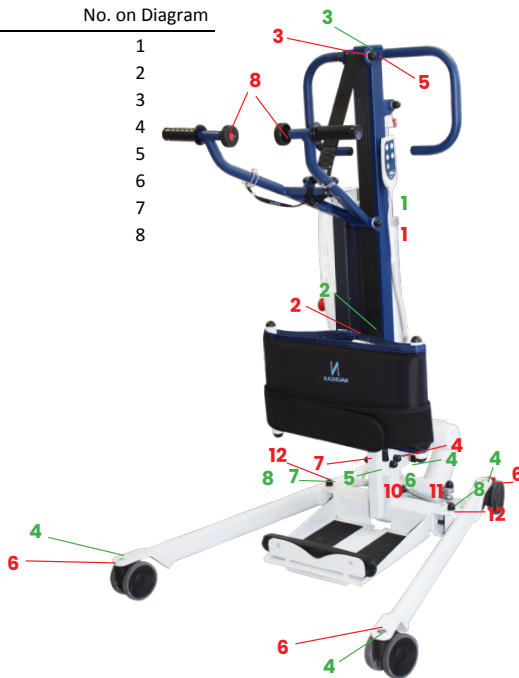



# Spare parts

## EASYLEV5

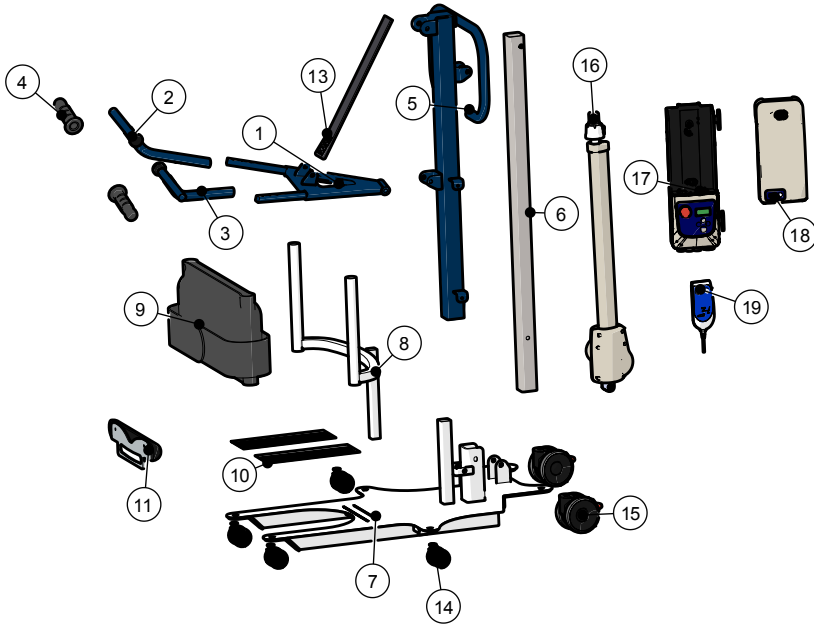

NUMBER	DESIGNATION	REFERENCE
0	COMPLETE LIFTING ARM FOR EASYLEV 5 (1+2+3+4)	ESL5-BRS-PF
2	RIGHT HANDLE FOR RANGE 5 LIFTING ARM	WP5-BRSD-PF
3	LEFT HANDLE FOR RANGE 5 LIFTING ARM	WP5-BRSG-PF
4	LIFTING ARM GRIP HANDLES (set of 2 )	WP-PGN-PF
5	MOBILE MAST FOR EASYLEV 5	ESL5-MT-PF
6	INTERNAL MAST FOR EASYLEV 5	ESL5-FR-PF
7	FIXED BASE FOR EASYLEV 5	ESL5-EMB-PF
8	SHIN BLOCK SHORT SUPPORT (without foam) FOR RANGE 5	WP5-CTB-PF
9	KNEE FOAM SUPPORT FOR EASYLEV AND WAYUP 5	WP5-BASR-PF
10	NON-SKID (2 pieces)	WP5-ADAD-PF
11	HEEL BLOCK FOR RANGE 5	WP5-CLT-PF
12	TRACTION SLING FOR EASYLEV 5	ESL5-STR-PF
13	FRONT AND SIDE WHEELS FOR EASYLEV AND WAYUP 5 WITH FIXED BASE	WP5-RJND50-PF
14	REAR WHEELS FOR EASYLEV AND WAYUP 5 WITH FIXED BASE	WP5-RJNFRD100-PF
15	3000N LIFTING ACTUATOR FOR EASYLEV 5	VSVRN-ESL5
16	CONTROL BOX VEOBOX 3 2 FUNCTIONS (without battery pack)	VS-BCC3
17	REMOVABLE BATTERY PACK (with 2 internal batteries 5A/12V) WITH LOAD DISPLAY AND BALANCING	CBPB+PF ou CBLI-PF
18	2 FUNCTIONS REMOTE CONTROL FOR VEOBOX 3	VS-TLCM3
19	LIGHT GREY SPRAY PAINT	WP-BPGL
20	SAPHIR BLUE SPRAY PAINT	WP-BPBS
21	LIGHT GREY STICKER	WP-VGL
22	SAPHIR BLUE STICKER	WP-VBS

# Spare parts

## EASYLEV 5 with mechanical opening legs

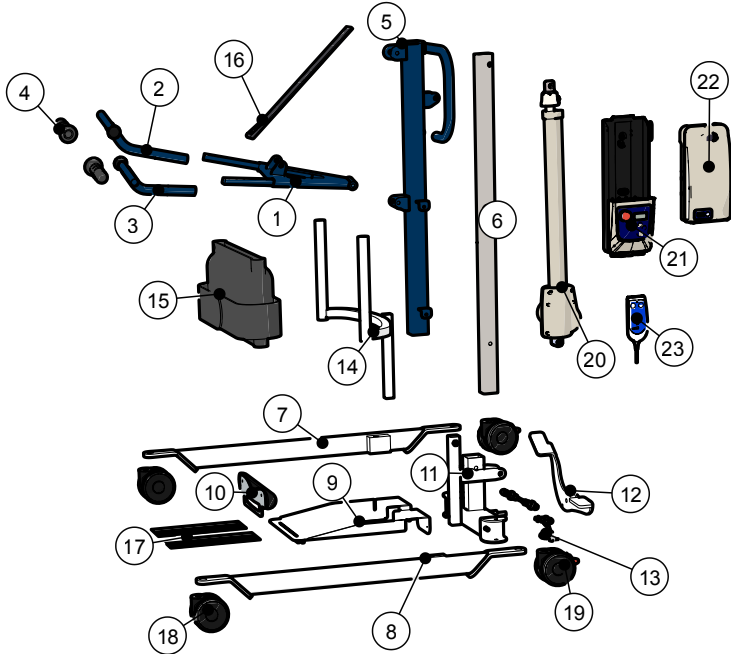

NUMBER	DESIGNATION	REFERENCE
0	COMPLETE LIFTING ARM FOR EASYLEV 5 (1+2+3+4)	ESL5-BRS-PF
2	RIGHT HANDLE FOR RANGE 5 LIFTING ARM	WP5-BRSD-PF
3	LEFT HANDLE FOR RANGE 5 LIFTING ARM	WP5-BRSG-PF
4	LIFTING ARM GRIP HANDLES (set of 2 )	WP-PGN-PF
5	MOBILE MAST FOR EASYLEV 5	ESL5-MT-PF
6	INTERNAL MAST FOR EASYLEV 5	ESL5-FR-PF
7	RIGHT FOOT FOR EASYLEV AND WAYUP 5	WP5-EP-PD-PF
8	LEFT FOOT FOR EASYLEV AND WAYUP 5	WP5-EP-PG-PF
9	REMOVABLE PLATFORM FOR EASYLEV AND WAYUP 5	WP5-EP-PLA-PF
10	HEEL BLOCK FOR RANGE 5	WP5-CLT-PF
11	BASE FOR EASYLEV 5 OBL	ESL5-ECP-EMB-PF
12	FOOT PEDAL FOR EASYLEV AND WAYUP 5	WP5-PD-PF
13	SPREADING SYTEM SET FOR EASYLEV AND WAYUP OBL (without pedal)	WP-EP2-PF
14	SHIN BLOCK SHORT SUPPORT (without foam) FOR RANGE 5	WP5-CTB-PF
15	KNEE FOAM SUPPORT FOR EASYLEV AND WAYUP 5	WP5-BASR-PF
16	TRACTION SLING FOR EASYLEV 5	ESL5-STR-PF
17	FRONT WHEELS FOR EASYLEV AND WAYUP 5 OBL	WP5-ADAD-PF
18	FRONT WHEELS FOR EASYLEV AND WAYUP 5 OBL	WPEP-RJND100-PF
19	REAR WHEELS FOR EASYLEV AND WAYUP 5 OBL	WPEP-RJNFRD100-PF
20	3000N LIFTING ACTUATOR FOR EASYLEV 5	VSVRN-ESL5
21	CONTROL BOX VEOBOX 3 2 FUNCTIONS (without battery pack)	VS-BCC3
22	REMOVABLE BATTERY PACK (with 2 internal batteries 5A/12V) WITH LOAD DISPLAY AND BALANCING	CBPB+-PF ou CBLI-PF
23	2 FUNCTIONS REMOTE CONTROL FOR VEOBOX 3	VS-TLCM3
24	LIGHT GREY SPRAY PAINT	WP-BPGL
25	SAPHIR BLUE SPRAY PAINT	WP-BPBS
26	LIGHT GREY STICKER	WP-VGL
27	SAPHIR BLUE STICKER	WP-VBS

# Spare parts

## EASYLEV 5 Plus with electrical opening legs

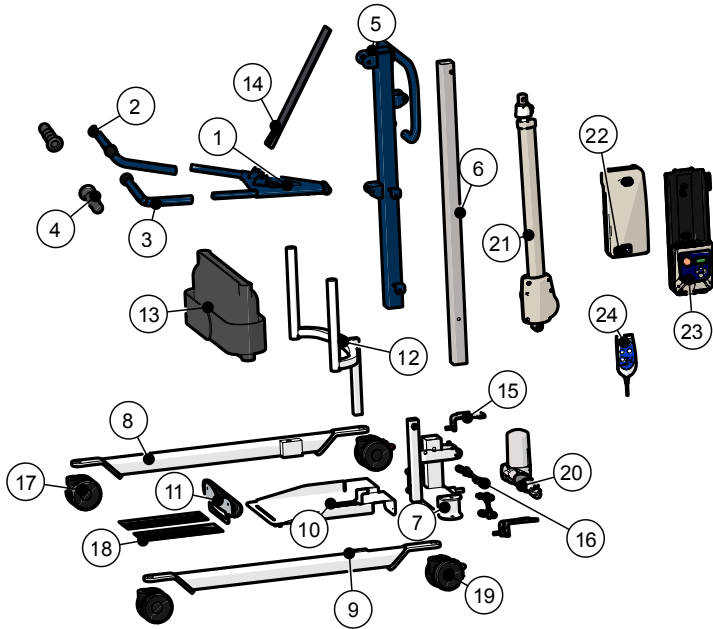

NUMBER	DESIGNATION	REFERENCE
0	COMPLETE LIFTING ARM FOR EASYLEV 5 (1+2+3+4)	ESL5-BRS-PF
2	RIGHT HANDLE FOR RANGE 5 LIFTING ARM	WP5-BRSD-PF
3	LEFT HANDLE FOR RANGE 5 LIFTING ARM	WP5-BRSG-PF
4	LIFTING ARM GRIP HANDLES (set of 2 )	WP-PGN-PF
5	MOBILE MAST FOR EASYLEV 5	ESL5-MT-PF
6	INTERNAL MAST FOR EASYLEV 5	ESL5-FR-PF
7	BASE FOR EASYLEV 5 OBL	ESL5-ECP-EMB-PF
8	RIGHT FOOT FOR EASYLEV AND WAYUP 5	WP5-EP-PD-PF
9	LEFT FOOT FOR EASYLEV AND WAYUP 5	WP5-EP-PG-PF
10	REMOVABLE PLATFORM FOR EASYLEV AND WAYUP 5	WP5-EP-PLA-PF
11	HEEL BLOCK FOR RANGE 5	WP5-CLT-PF
12	SHIN BLOCK SHORT SUPPORT (without foam) FOR RANGE 5	WP5-CTB-PF
13	KNEE FOAM SUPPORT FOR EASYLEV AND WAYUP 5	WP5-BASR-PF
14	TRACTION SLING FOR EASYLEV 5	ESL5-STR-PF
15	ELECTRICAL OPENING BASE LEGS COMPLETE SET (3 metallic pieces,without rod, without actuator)	WP5-KEPE-PF
16	SPREADING SYTEM SET FOR EASYLEV AND WAYUP OBL (without pedal)	WP-EP2-PF
17	FRONT WHEELS FOR EASYLEV AND WAYUP 5 OBL	WPEP-RJND100-PF
18	NON-SKID (2 pieces)	WP5-ADAD-PF
19	REAR WHEELS FOR EASYLEV AND WAYUP 5 OBL	WPEP-RJNFRD100-PF
20	SPREADING SYTEM SET FOR EASYLEV AND WAYUP OBL (without pedal)	VSVRN-ECP3
21	3000N LIFTING ACTUATOR FOR EASYLEV 5	VSVRN-ESL5
22	REMOVABLE BATTERY PACK (with 2 internal batteries 5A/12V) WITH LOAD DISPLAY AND BALANCING	CBPB+-PF ou CBLI-PF
23	CONTROL BOX VEOBOX 3 4 FUNCTIONS	VS-BCC3-ECP
24	4 FUNCTIONS REMOTE CONTROL FOR VEOBOX 3	VS-TL3M3-ECP
25	LIGHT GREY SPRAY PAINT	WP-BPGL
26	SAPHIR BLUE SPRAY PAINT	WP-BPBS
27	LIGHT GREY STICKER	WP-VGL
28	SAPHIR BLUE STICKER	WP-VBS

# Spare parts

## Control Box : 2 Functions

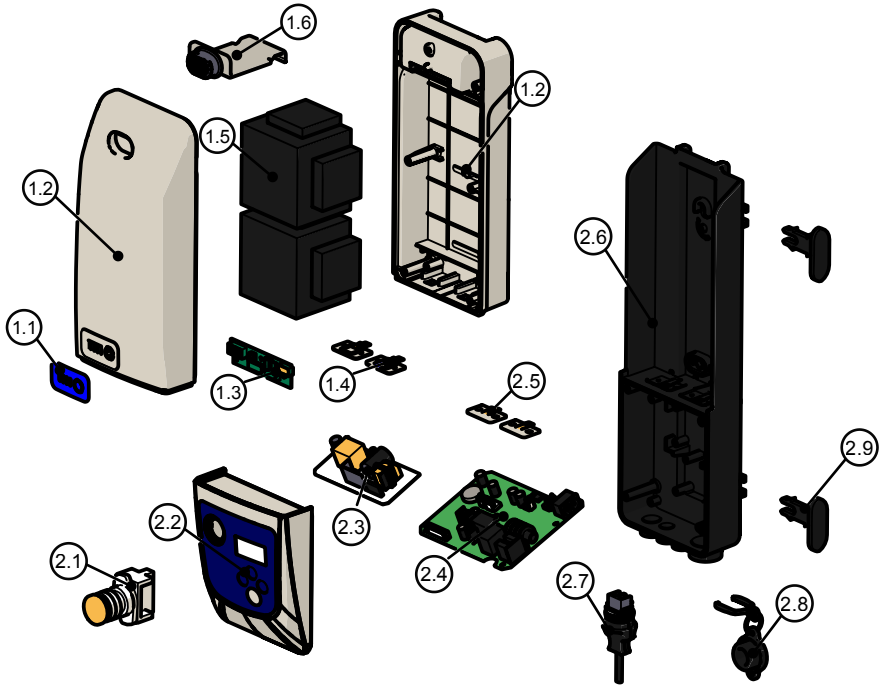

NUMBER	DESIGNATION	REFERENCE
1	REMOVABLE BATTERY PACK (with 2 internal batteries 5A/12V) WITH LOAD DISPLAY AND BALANCING	CBPB+-PF or CBLI-PF
1.1	BATTERY PACK ADHESIVE FRONTAGE DISPLAY FOR VS-BCAM	VS-BCAM-FAE
1.2	BATTERY PACK COMPLETE CASING	VS-BCAM-CAR
1.3	2 ELECTRONIC BOARDS SET (display and balancing) FOR BATTERY PACK VS-BCAM	VS-BCAM-KCRT
1.4	CONNECTION KIT WITH FUSES FOR BATTERY PACK VS-BCAM OU VS-BCAM-SMP	VS-BCAM-KCFC
1.5	INTERNAL BATTERIES	F3-BT2IN
1.6	BATTERY PACK HOOK FASTENING	VS-BCAM-CR
2	CONTROL BOX VEOBOX 3 2 FUNCTIONS (without battery pack)	VS-BCC3
2.1	COMPLETE EMERGENCY STOP BUTTON	VS-BAUR
2.2	CONTROL BOX FRONT COVER FOR VEOBOX 3 2 FUNCTIONS	VS-BCC3-CAR-AV
2.3	CONTROL BOARD WITH DISPLAY FOR VEOBOX 3 2 FUNCTIONS	VS-BCC3-BA
2.4	CONTROL BOARD FOR VEOBOX 3 2 FUNCTIONS	VS-BCC3-CCC
2.5	CONNECTION KIT WITH FUSES FOR CONTROL BOARD VS-BCC-CCC AND VS-BCC-CCC-ECP	VS-KCNF
2.6	CONTROL BOX REAR COVER FOR VEOBOX 3 2 & 4 FUNCTIONS	VS-BCC3-CAR-AR
2.7	POWER CORD	VS-CRD
2.8	CONTROL BOX POWER CORD INPUT PLUG	VS-BCH
2.9	POWER CORD REWINDER HOOK (set of 2)	VS-ERL

# Spare parts

## Control Box : 4 Functions

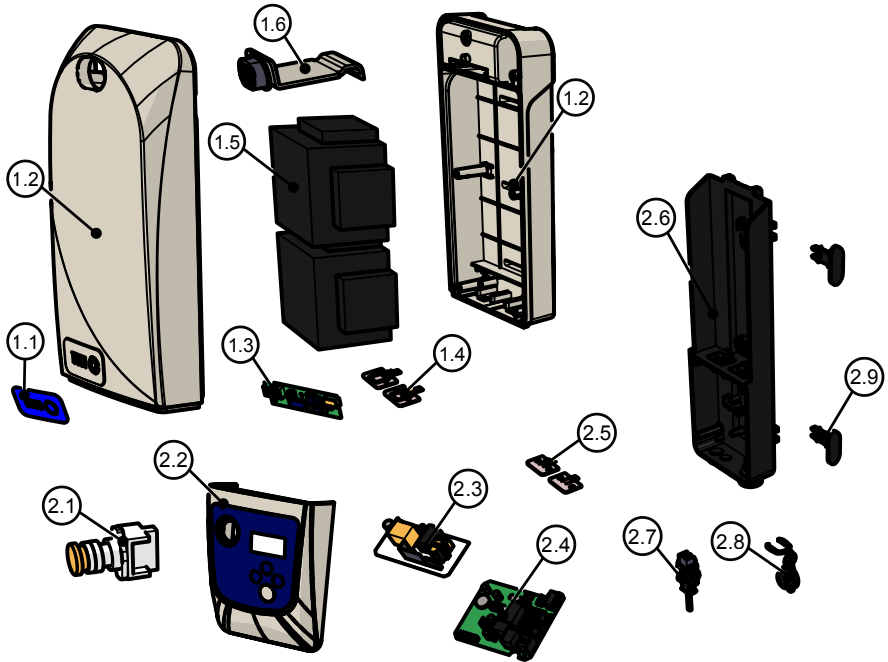

NUMBER	DESIGNATION	REFERENCE
1	REMOVABLE BATTERY PACK (with 2 internal batteries 5A/12V) WITH LOAD DISPLAY AND BALANCING	CBPB+-PF or CBLI-PF
1.1	BATTERY PACK ADHESIVE FRONTAGE DISPLAY FOR VS-BCAM	VS-BCAM-FAE
1.2	BATTERY PACK COMPLETE CASING	VS-BCAM-CAR
1.3	2 ELECTRONIC BOARDS SET (display and balancing) FOR BATTERY PACK VS-BCAM	VS-BCAM-KCRT
1.4	CONNECTION KIT WITH FUSES FOR BATTERY PACK VS-BCAM OU VS-BCAM-SMP	VS-BCAM-KCFC
1.5	BATTERY PACK HOOK FASTENING	VS-BCAM-CR
1.6	INTERNAL BATTERIES	F3-BT2IN
2	CONTROL BOX VEBOX 3 4 FUNCTIONS	VS-BCC3-ECP
2.1	COMPLETE EMERGENCY STOP BUTTON	VS-BAUR
2.2	CONTROL BOX FRONT COVER FOR VEBOX 3 4 FUNCTIONS	VS-BCC3-ECP-CAV
2.3	CONTROL BOARD WITH DISPLAY FOR VEBOX 3 4 FUNCTIONS	VS-BCC3-BA
2.4	CONTROL BOARD FOR VEBOX 3 4 FUNCTIONS	VS-BCC3-CCC-ECP
2.5	CONNECTION KIT WITH FUSES FOR CONTROL BOARD VS-BCC-CCC AND VS-BCC-CCC-ECP	VS-KCNF
2.6	CONTROL BOX REAR COVER FOR VEBOX 3 4 FUNCTIONS	VS-BCC3-ECP-CAR
2.7	POWER CORD	VS-CRD
2.8	CONTROL BOX POWER CORD INPUT PLUG	VS-BCH
2.9	POWER CORD REWINDER HOOK (set of 2)	VS-ERL

# Spare parts

## Remote control : 2 Fonctions

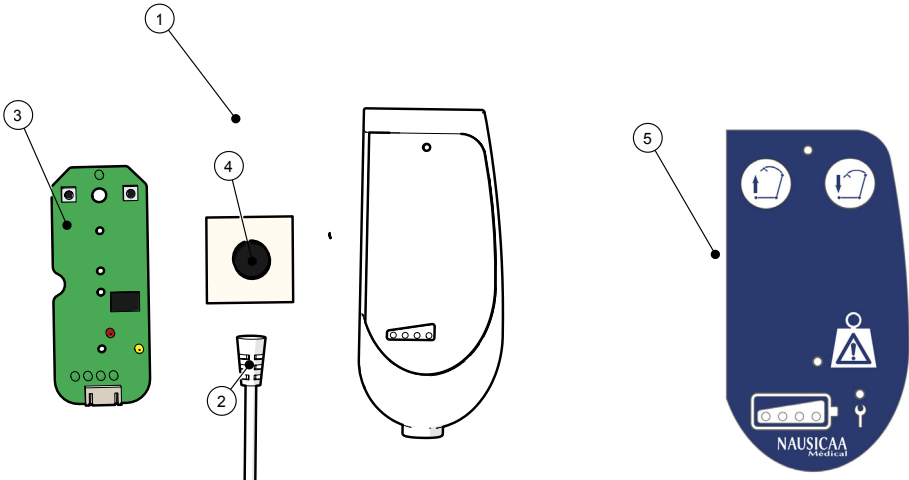

NUMBER	DESIGNATION	REFERENCE
1	2 FUNCTIONS REMOTE CONTROL FOR VEOBOX 3	VS-TLCM3
2	CORD FOR 4 FUNCTIONS REMOTE CONTROL FOR VEOBOX 3	VS-TLCM3-CRD
3	CONTROL BOARD FOR 2 FUNCTIONS REMOTE CONTROL FOR VEOBOX 3	VS-TLCM3-CCC
4	MAGNET FOR REMOTE CONTROL	VS-AMTL-PF
5	FRONT LABEL FOR REMOTE CONTROL 2 FUNCTIONS FOR VEOBOX 3	VS-TLCM3-FA

## Remote control : 4 Fonctions

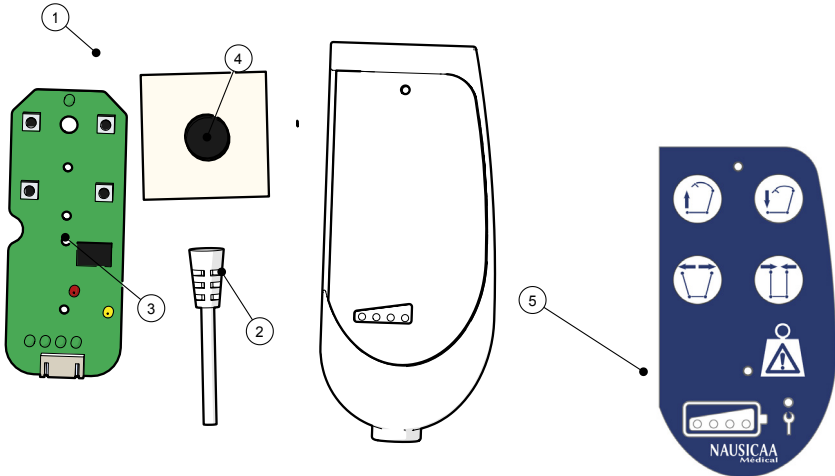

NUMBER	DESIGNATION	REFERENCE
1	4 FUNCTIONS REMOTE CONTROL FOR VEOBOX 3	VS-TLCM3-ECP
2	CORD FOR 4 FUNCTIONS REMOTE CONTROL FOR VEOBOX 3	VS-TLCM3-CRD-ECP
3	CONTROL BOARD FOR 4 FUNCTIONS REMOTE CONTROL FOR VEOBOX 3	VS-TLCM3-CCC-ECP
4	MAGNET FOR REMOTE CONTROL	VS-AMTL-PF
5	FRONT LABEL FOR REMOTE CONTROL 4 FUNCTIONS FOR VEOBOX 3	VS-TLCM3-ECP-FA

# Spare parts

## Jack 3 000 Newtons

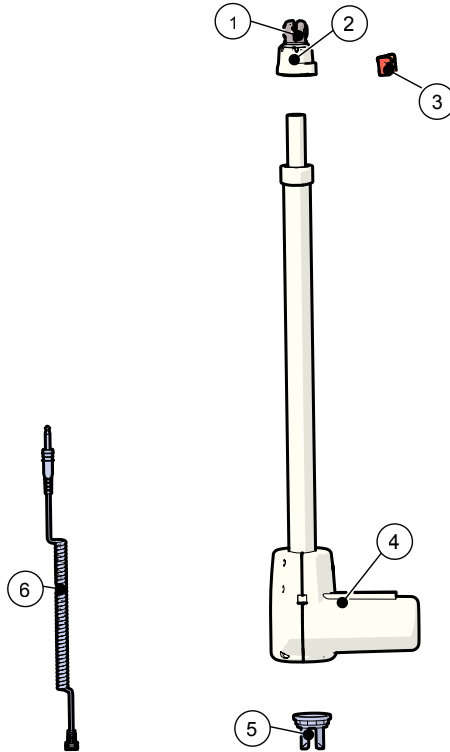

NUMBER	DESIGNATION	REFERENCE
0	COMPLETE CONTINUED EMERGENCY LOWERING SYSTEM FOR ACTUATOR (without the screed) "1+2+3"	VS-VRN-DMC
1	HEAD SCREED FOR ACTUATOR WITH EMERGENCY LOWERING SYSTEM (all models)	VS-VRN-CHT
2	COMPLETE CONTINUED EMERGENCY LOWERING SYSTEM CASING FOR ACTUATOR (all models)	VS-VRN-DM-CAR
3	EMERGENCY LOWERING SYSTEM 2 RED BUTTONS SET (all models)	VS-VRN-KBPR
4	8000N (all models) AND 3000N (VSNLV-VRN) LIFTING ACTUATORS COMPLETE CASING	VS-VRN-8-CAR
5	LIFTING ACTUATOR BASE SCREED FOR EASYLEV	VS-NLVVRN-CEMB
6	6000N AND 8000N LIFTING ACTUATORS CORD (all models)	VS-VRN-6-8-CRD

# Spare parts

## Opening Legs Jack 3 000 Newtons

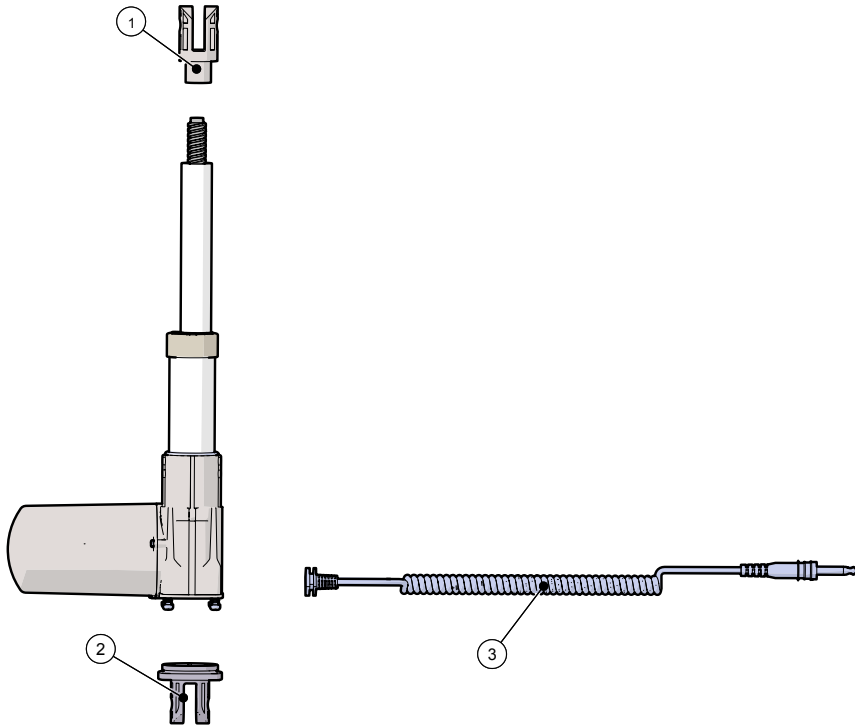

NUMBER	DESIGNATION	REFERENCE
1	3000N OPENING BASE LEGS GREY ACTUATOR	VSVRN-ECP3
2	3000N OPENING BASE LEGS GREY ACTUATOR HEAD SCREED	VS-VRN-ECP3-CHT
3	3000N OPENING BASE LEGS GREY ACTUATOR BASE SCREED	VS-VRN-ECP3-CEMB
4	3000N OPENING BASE LEGS GREY ACTUATOR CORD	VSVRN-ECP3-CRD



# Troubleshooting guide

Main symptom	Refined symptom	Cause	Solution
The unloaded device does not always go down.	The device runs empty.	Our devices need to have a weight exerted on them in order to be lowered.	Push down on the lifting arm while pressing the down button on the remote control.
The moving parts of the devices are hard, the device is hard to handle.	Problem of rolling, of knee supports adjustment.	This is due to a lack of lubrication of the moving parts.	Lubricate the moving parts.
The actuator does not work but we hear a "click" in the control box when pressing the remote control.	Battery level remains displayed on the pack even while pressing on the remote.	The batteries are discharged or worn out.	Charge the device or change the batteries.
	Battery level off while pressing the remote control.	The motherboard is defective.	Change the motherboard.
The actuator does not work and there is no "click" sound in the control box when the remote control is pressed.	Battery level off while pressing the remote control.	Actuator cable is not connected or damaged.	Reconnect the actuator cable or if it is damaged, repair it.
	Battery is charged on direct current (flashing battery level display) but no display on the control box if it is disconnected from the direct current.	Emergency stop button is pressed or defective.	Disengage the emergency stop button or change it.
	Battery recharged to the direct current (battery level display on 4 bars) but no display on the control box if it is disconnected from the direct current.	The contact between the battery and the control box is not present.	Remove and replace the battery, making sure that the two parts are in contact.
	Battery recharged to the direct current (battery level display on 4 bars) but no display on the control box if it is disconnected from the direct current.	The battery is too worn or too discharged to be recharged.	Change the battery.
	Battery is charged on direct current (blinking battery level display) and normal display on the control box if it is disconnected from the direct current.	One of the fuses T10A (one in the control box and one in the battery cartridge) is cut.	Replace the faulty fuse(s).
	In all other cases.	The remote control is out of service (check if the device works with the buttons on the control box).	Change the remote control.
		The motherboard is defective.	Change the motherboard.
The actuator stops intermittently.	Only when the patient is hanging from the sling during the lifting movement.	The batteries are discharged or worn out.	Charge the device or change the batteries.
		The weight lifted by the device is too important, a weight symbol is displayed on the screen.	Decrease the weight lifted by the unit by relieving the load on the lifting arm.
	Device empty and/or being lowered	The duty cycle of the actuator is reached (self-preservation), an actuator is displayed on the screen.	Do not use the device for at least 20 minutes.
		The thermal protection of the actuator has been activated.	Allow the actuator to cool down.
		The batteries are discharged or worn out.	Charge the device or change the battery.
		The motherboard is defective.	Change the motherboard.
The battery no longer holds the charge.	On direct current, the battery level flashes then becomes fixed in a short time (<5 hours for a fully discharged battery).	The batteries are worn.	Change the battery.
	On direct current, the battery level does not blink, it becomes fixed right away.	The batteries are worn.	Change the battery.
	On direct current, nothing happens.	One of the fuses T10A (one in the control box and one in the battery cartridge) is cut.	Replace the faulty fuse(s).
		Check that the electrical outlet is functional.	Change de prise de courant
		Check if the power cord is not damaged.	Change the power cord.
		One of the T1A fuses is cut (on VEOBOX 1 and 2)	Replace the faulty fuse(s).
		The internal case charger is out of service (on VEOBOX 3).	Change the internal charger.
The motherboard is defective (on VEOBOX 1 and 2).	Change the motherboard.		



# Warranty

---

• Article 1 : NAUSICAA Médical S.A.S. warrants this product against any defects in manufacturing and assembly of mechanical and electronic components. This warranty is for devices used only in accordance with NAUSICAA Médical S.A.S. terms of use.

The warranty covers all mechanical and electrical parts, except battery and breakage.

This warranty whose terms of use are defined below is valid for lithium battery: 2 years guarantee, lead battery: 1 year guarantee from the date of first departure from NAUSICAA Médical S.A.S.

• Article 2 : The warranty entitles the free labor and the free replacement of defective parts.

• Article 3 : The original out-going shipping costs of the device and all associated costs are the responsibility of the distributor. The goods always travel at the risk and the responsibility of the distributor.

Under warranty : return costs after intervention will be borne by NAUSICAA Médical S.A.S.

Out of warranty: return costs are at the expense of the distributor whether or not he accepts the repair estimate.

• Article 4 : The warranty does not apply if the claims are consecutive to:

- accident, misuse or neglect of the unit by the end customer.

- shipping performed without adequate protection.

- alteration or transformation not validated by NAUSICAA Médical S.A.S.

- the impact of external elements (natural disaster, fire, shock, humidity, flood, lightning, ...).

- installation and/or use in a non-compliant way with technical standards and safety (in case the unit would work in a country other than the country of origin) ; and/or if the electrical power is not suited for the operating voltage of the device.

- a lack of routine maintenance.

• Article 5 : The distributor may not invoke the benefit of the warranty:

- if the device serial number has been removed, altered or rendered illegible.

- if the device under warranty has been modified without the approval of NAUSICAA Médical S.A.S.

• Article 6 : During the repair of any defective equipment, no loan will be made.

• Article 7 : All warranty claims must be exercised through the distributor.

• Article 8 : Sending spare parts under warranty will be made after consultation with the distributor customer service.

• Article 9 : Defective parts changed under or out of warranty will be guaranteed for 6 months from the date of repair or sending of the spare parts.

• Article 10 : No distributor can unilaterally change the terms of this warranty.

# NAUSICAA

MEDICAL

Head Office Sales Department

Telephone: 04 66 51 50 80

Fax: 04 66 51 50 47

Mail: [contact@nausicaa-medical.com](mailto:contact@nausicaa-medical.com)

[www.nausicaa-medical.com](http://www.nausicaa-medical.com)

Your contact :

Manufactured by NAUSICAA Médical S.A.S.



NAUSICAA  
MEDICAL

12 Allée du Piot - ZA Pôle Actif  
30660 Gallargues le Montueux  
FRANCE